

### OVERVIEW

EW Series electronic metering pumps offer superior dosing capability. The versatile control features enable the EW to be integrated into virtually any chemical feed application. Superb valve performance and advanced solenoid engineering combine to make a highly precise pump for the most demanding applications.

EW pumps have outputs to 6.7 GPH (25.2 l/h) and a maximum pressure of 250 PSI (17 bar). The high speed of operation results in high resolution chemical feed and long service life. Quiet and compact, EW pumps prime in seconds and hold prime reliably.



### SUMMARY OF KEY BENEFITS



#### High Speed Performance

E-Class pumps operate at 360 strokes-per-minute, providing high resolution chemical feed. Most competitive products operate at slower speeds, resulting in slug feeding, accelerated diaphragm wear and poor feed control.



#### Engineered Longevity

All E-Class pumps feature dual bearing support. The armature and shaft are supported with a bearing on each end, which ensures proper axial movement, enabling the E-Class to operate at 360 SPM while extending the life of the diaphragm.



#### Superior Check Valve Performance

Dual Check Valve Assemblies in both suction and discharge fittings feature precision ball guides and tapered seats. Precise machining and molding of parts limit valve ball travel, ensuring that balls fully seat and seal with every stroke. This superior check valve design guarantees fast priming and reliable performance.



#### High Compression Ratio

The compression ratio of a metering pump is important because it affects the pump's ability to prime and vent. The compression ratio is raised when you reduce the dead volume of the pump head during operation. All E-Class pumps feature a very high compression ratio that ensures proper feed especially with off-gassing products (i.e. Sodium Hypochlorite).

## IP65 Construction

The rugged Polyphenylene Oxide (PPO) enclosure is equipped with a durable clear cover to protect the membrane switches and stroke control of the pump, which are mounted opposite the liquid end. The display utilizes a high temperature LCD that provides extra protection from sunlight in outdoor applications.



PVC

GFRPP

PVDF

316SS

## Control Features

All EW Series pumps come equipped with pulse and stop input/output control.

- » Feed Accuracy - Powered by the E-Class 360 Stroke-Per-Minute technology, the EW has an incredible turndown ratio of 1800:1 ensuring precise feed control for any application.
- » Pulse Output - The EW pump is capable of sending a pulse out synchronous with pump operation to control a second pump or connect to a PLC or similar device.
- » Stop Input/Output - A stop input contact will stop the pump operation and close a stop output contact for alarm or remote notification. A red light visibly indicates a stopped condition.
- » Pre-Stop Input - An orange indicator light will give warning, but the pump will continue to operate.



In addition to the features found standard on the EW Series, pumps with the EW-Y control module feature:

- » Analog Input Control - Fixed or fully programmable response to mA input (4-20, 20-4, 0-20, 20-0) allows the input to be scaled to any desired slope.
- » Pulse Input Control - Pulse input with multiply and divide features (1-9999). 12VDC output power supply for Hall Effect water meters.
- » Flow Display - After calibration the EW will display the flow rate. As long as stroke length is constant, the pump will accurately display flow rate. In cases where the pump is being controlled externally with a pulse, the pump will display and count down remaining flow based on the pulse input. Coupled with the Posiflow® feed verification, the EW is equipped to ensure proper feed to your application.
- » Feed Verification - The EW is equipped with 3 pre-programmed modes for accepting our Posiflow® Feed Verification Sensor. The Posiflow® provides a pulse feedback to the pump to verify prime and proper feed. Depending on the mode, the user can program the pump to stop, continue operating and/or send an alarm based on the Posiflow® input.
- » Quick-Prime - Hold 2 keys down and pump runs at 100% of speed to prime quickly without adjusting application settings.
- » Keypad Lock-Out - Keypad functions can be locked out providing feed security, programming integrity and protection from unwanted adjustments.
- » Easy Draw-Down Calibration - In the calibration mode the user only needs to start and stop the pump, enter the draw-down volume and the pump calibrates volume-per-stroke.



**2-YEAR WARRANTY**  
**'Bumper-to-Bumper' on all**  
**E-Class Pumps**  
**including Wetted Parts**

## Electrical Specifications

EW	EWB	EWC
50/60 Hz, single phase	20 Watt avg.	22 Watt avg.
115 VAC ±10%	0.8 Amp max.	1.2 Amp max.
230 VAC ±10%	0.4 Amp max.	0.6 Amp max.

## Safety Certifications

The EW series metering pumps are WQA tested and certified to NSF/ANSI Standard 61.



Shipping Weight	12 lbs. (5.5 kg)	14 lbs. (6.4 kg)
-----------------	------------------	------------------

The EW series metering pumps are tested by Intertek to UL and CSA standards.



## Operating Conditions

Ambient Temperature:	32 to 122°F (0 to 50°C)	
Relative Humidity:	to 85%	
Liquid Temperature:	PVC liquid ends:	32 to 104°F (0 to 40°C)
	PP, PVDF, SS liquid ends:	32 to 140°F (0 to 60°C)
	Below 32°F (0°C), pump is limited to 70% of maximum pressure. Liquid cannot freeze.	

## Dimensions

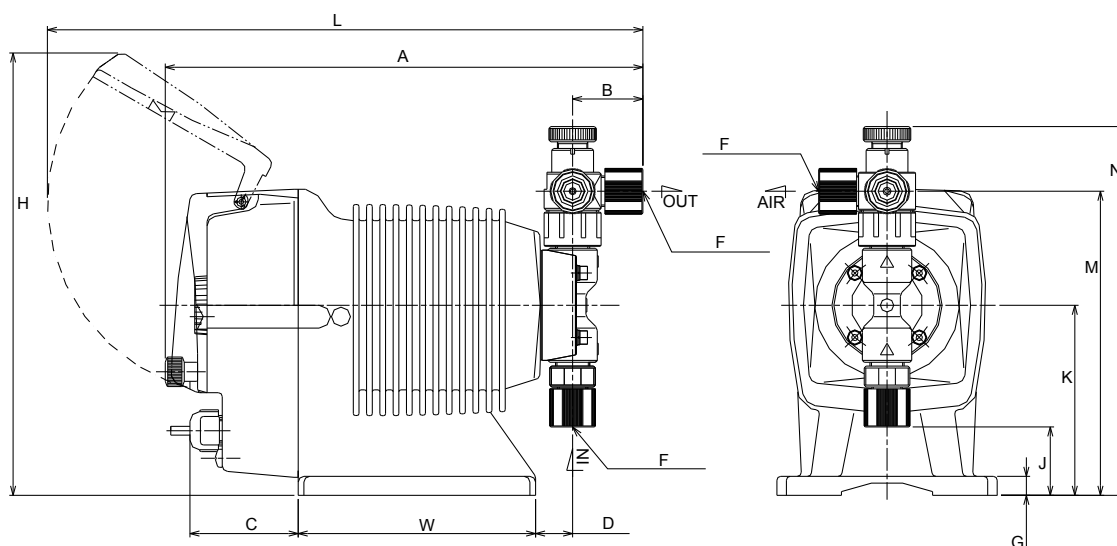

### Mounting Dimensions

EW Model	R	S	T	U	V	X	Y	Z
11, 16, 21	4.57"	3.94"	0.24"	3.15"	4.17"	1.57"	0.59"	0.79"
31, 36								

all dimension in inches

EW Model	A	B	C	D	F	G	H	J	K	L	M	N	W
11, 16, 21	9.92 <sup>1</sup>	1.46 <sup>1</sup>	2.24	0.77	ø <sup>1</sup> / <sub>4</sub> x ø <sup>3</sup> / <sub>8</sub>	0.39	9.17	1.42	3.94	12.36 <sup>1</sup>	6.30 <sup>2</sup>	7.64 <sup>1</sup>	4.92
31, 36	10.12	1.50	2.24	0.93	ø <sup>3</sup> / <sub>8</sub> x ø <sup>1</sup> / <sub>2</sub>	0.39	9.17	0.71	3.94	12.56	7.17	8.43	4.92

Notes for EW11, 16, 21:

1. Addition of a Multifunction valve increases overall length by 0.37". Addition of an Auto Air Vent Valve increases overall length by 1.59"
2. Addition of a Multifunction Valve increases discharge height by 0.22". No change for the Auto Air Vent Valve.
3. Addition of a Multifunction Valve increases overall liquid end height by 1.16". No change for the Auto Air Vent Valve.

## ORDER INFORMATION

EW B16 F 1 — VC A  
 Pump Capacity/ Control Voltage Liquid Options  
 series Pressure Module End

### PUMP SERIES

EW = IP65 electronic metering pump with external pulse control or manual speed control (adjustable to 360 strokes per minute) and manually adjustable stroke length. (Turndown ratio 1800:1)

### CAPACITY/PRESSURE RATING

See chart on this page

### CONTROL MODULE

F = For use on all EW models, features digitally adjustable speed and external pulse input control, stop & pre-stop inputs.

Y = For use on all EW models, features analog input, digital input w/multiply & divide, PosiFlow® input and alarm outputs.

### VOLTAGE

1 = 115VAC, 50/60 Hz  
 2 = 230VAC, 50/60 Hz

### LIQUID END

See chart on this page

### OPTIONS

A = Auto Air Vent Valve installed in place of manual air vent valve. Available for B11, B16, C16 and C21 sizes with -VC liquid ends only.

M = Multifunction Valve is supplied in place of the manual air vent valve. Available for the 11, 16 and 21 size pumps with VC, VE, VF, PC, and PE liquid ends. Not available with the AAVV feature.

H = High pressure pump configuration available with PC, PE liquid ends only. High pressure pump max. speed is 240 SPM.

### CONNECTORS (SOLD SEPARATELY)

**E90494** 4-Pin, Reverse Key Connector. Use for Stop/Pre-Stop inputs on EW/EW-Y.

**E90495** 5-Pin Connector. Use for Pulse in and Outputs on EW. Use for digital or analog inputs on EW-Y. Supplied standard with EW-Y pumps.

**E90496** 5-Pin, Reverse Key Connector. use for Posiflow® input on EW-Y.

**E90497** 4-Pin Square Connector. Use for output connectors on EW-Y.

All pumps include a manual air vent valve with the exception of FC liquid ends. All pumps include one foot valve, one injection valve, 20 feet of polyethylene tubing and one ceramic weight with the exception of SH liquid ends.



## Capacity/Pressure Rating

Size	Max Output Capacity		Max output per stroke	Max Pressure <sup>1</sup>		Connection Size (in) Tubing O.D.
	GPH	mL/min	mL	PSI	MPa	
B11	0.6	38	0.11	150	1.0	3/8
B11-H	0.3	21	0.09	250	1.7	3/8 (suc) x 1/4 NPT (dis)
B16	1.0	65	0.18	105	0.7	3/8
B21	1.8	115	0.32	60	0.4	3/8
B31	3.3	210	0.58	30	0.2	1/2
C16	1.3	80	0.22	150	1.0	3/8
C16-H	0.6	40	0.17	250	1.7	3/8 (suc) x 1/4 NPT (dis)
C21	2.3	145	0.40	105	0.7	3/8
C31	4.3	270	0.75	50	0.35	1/2
C36 <sup>2</sup>	6.7	420	1.17	30	0.2	1/2

1 Auto Air vent valve reduces maximum pressure approx. 35 PSI (0.2 MPa)

2 Output of the EWC36-TC/FC/SH is 6.3 GPH (400 ml/min)

## Liquid End Materials

Liquid End	Pump Head & Fittings	Diaphragm	Valve Balls	Valve Seat	Valve Seals	Gasket	Tubing
PC	GFRPP	PTFE (bonded to EPDM)	CE	FKM	FKM	PTFE	PE
PE	GFRPP		CE	EPDM	EPDM		
VC	PVC		CE	FKM	FKM		
VE	PVC		CE	EPDM	EPDM		
VF	PVC		PTFE	EPDM	EPDM		
TC	PVDF		CE	FKM	FKM		
FC	PVDF		CE	PCTFE	PTFE		
SH	SS		HC	HC	PTFE		

CE Alumina ceramic

FKM Fluoroelastomer

PE Polyethylene

PCTFE Polychlorotrifluoroethylene

PVDF Polyvinylidene fluoride

EPDM

GFRPP

PTFE

PVC

HC

Ethylene propylene diene monomer

Glass fiber reinforced polypropylene

Polytetrafluoroethylene

Polyvinylchloride (translucent)

Hastelloy C276

## ABOUT US

Walchem integrates its advanced sensing, instrumentation, fluid pumping and communications technologies to deliver reliable and innovative solutions to the global water treatment market.

Our in-house engineering is driven by quality, technology and innovation. For more information on the entire Walchem product line, visit: [www.walchem.com](http://www.walchem.com)

# WALCHEM

IWAKI America Inc.

Walchem, An Iwaki America Incorporated Company

Five Boynton Road Hopping Brook Park

Holliston, MA 01746 USA

Phone: 508-429-1110

Fax: 508-429-7433

[www.walchem.com](http://www.walchem.com)

180247.J Sept2012